

For filtering odours out of compressed air.

The activated carbon absorbs the oil vapour molecules contained in the compressed air.  
A separate filter route prevents activated carbon particles from entering the air flow.

Max. input pressure:	20 bar
Max. medium temperature:	60 °C
Max. ambient temperature:	60 °C
Drain vale:	Semi-automatic
Sealant:	NBR
Flow rate measurement:	At $P_1 = 6$ bar and pressure drop $\Delta p = 0.2$ bar
Residual oil content:	0.005 mg/m <sup>3</sup>
Filter element:	Activated carbon-POM

### Activated carbon filter with metal bowl

Art. No.	Type No.	Thread	Housing	Flow rate l/min	Size	DN
133152	FA 45 M	G 1	Die-cast aluminium	3000	4	25

### Accessories / spare parts

Art. No.	Type No.	Description
135858	ZW 45	Mounting bracket with 2 screws
135857	KP 45	Coupler pack for modular assembly of several devices
135863	KSS 45 NS	Polycarbonate bowl, without drain valve
135864	MS 45 NS	Metal bowl, without drain valve
100362	655.6.900	Automatic drain valve
100205	A 896	Filter element (activated carbon)

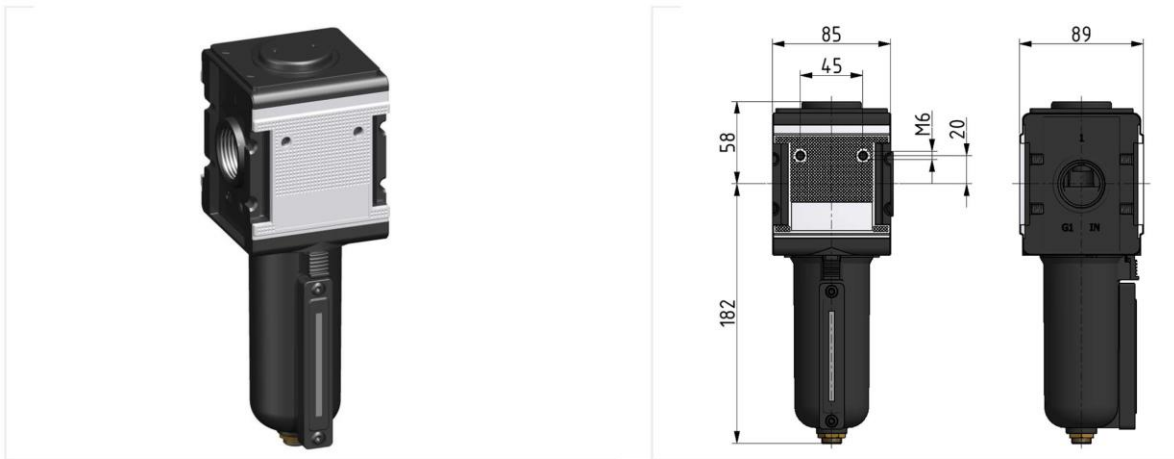

flow characteristic

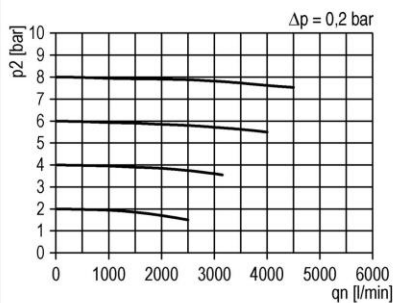

symbol

